



# Methodological Approach to the Selection of Filtering Materials for Injectable Medicines in Polyethylene Ampoules

Viacheslav Shevchenko<sup>1</sup>, Svitlana Rolik-Attia<sup>2</sup>, Yevhen Bezrukavyi<sup>3</sup>

<sup>1</sup>Department of Industrial Pharmacy and Economy, National University of Pharmacy of the Ministry of Health of Ukraine, Kharkiv, Ukraine

<sup>2</sup>Department of General Pharmacy and Safety of Drugs, National University of Pharmacy of the Ministry of Health of Ukraine, Kharkiv, Ukraine

<sup>3</sup>Department of Technologies of Pharmaceutical preparations, National University of Pharmacy of the Ministry of Health of Ukraine, Kharkiv, Ukraine

## KEYWORDS:

polyethylene ampoules,  
solution, filtration,  
piracetam 20%

## ABSTRACT

The aim of the has been studied is to select the optimal filter material to obtain a sterile injectable solution of piracetam 20%. One of the main requirements that apply to injection solutions is sterility and the absence of mechanical impurities. The filtration system must be reliable and easily controlled, since the use of filters that are not strong enough and clog the test solution with particles of the filter material leads to poor quality medicines. Therefore, it is necessary to constantly improve methods of filtration of parenteral drugs.

At the stage of pharmaceutical development, the influence of the filter membrane material on the quality of the solution to be filtered has been determined. A practical pattern of the choice of filters in the study of injectable solution of piracetam 20% and filter materials based on polyvinylidene fluoride (PVDF), polyester sulfone (PES) and nylon was provided. Studies have been conducted to identify possible processes of migration and sorption of solution components and filter membranes using instrumental methods of analysis, as well as to determine the sterilizing ability of filters with a membrane rating of not more than 0.2 μm.

The possibility of using all investigated filters in the commercial production of the medicine piracetam 20% has been proved. Using the results of this work will eliminate long-term and numerous studies on the selection of filter material during development of the technological stage of filtration in the production of injectable medicines.

## \* CORRESPONDING AUTHOR:

Viacheslav Shevchenko,  
e-mail: SVAVON@ ukr.net,  
promek-ipksf@nuph.edu.ua

## 1. Introduction

The main indicators of the quality of injection medicines include such indicators as mechanical inclusions: visible and invisible particles<sup>1,2</sup>. Achieving the regulated limits of this indicator is carried out not only by implementation of the requirements General Manufacturing Practice (GMP) in the production of drugs, but first of all, by carrying out one of the most important stages of the technological process - the prepared solution the filtration stage of. The development of new drugs, in addition to reformulation and formulation, includes the development of a technological process<sup>3</sup>, one of it is researching the choice of the stages on of filter material, determining the filtration efficiency through the selected filter and developing methods for monitoring filtration efficiency<sup>4</sup>. The final stage of the filtration process is the validation of filtration. It confirms that the process of filtration of the prepared solution during the technological process of obtaining the final product. The quality of attributes of product meets all the requirements of regulatory and technical documentation<sup>5</sup>.

Filtration is a complex of hydromechanical processes. Their efficiency of it has been determined by the properties of the separated dispersed media, the porous partition and the conditions of conduction. Filtration (as one of the key operations in the production of injectable dosage forms)<sup>6</sup>, requires the correct choice of filter unit, material and pore size of the filter; filtration rate etc.<sup>7</sup> In addition, the filtration system must be reliable and controlled easily. The use of filters (having no sufficient strength and contaminate the filtrate with particles of filter material), causes the need of purifying the solutions after the main filtration<sup>8</sup>.

The process of prepared solutions filtration is one of the most important stage in the technological process in the production of injectable medicines. Sterility and the absence of mechanical inclusions are important indicators of the quality of injectable solutions<sup>9,10</sup>. To ensure these indicators, the production of injectable medicines is carried out in appropriate conditions using some organizational

measures. They minimize the possibility of ingress microorganisms and mechanical inclusions into drugs at all stages of the technological process<sup>11,12</sup>. The most impotent stage among the measures is the stage of the technological process - filtration of the solution<sup>13</sup>.

Removal of mechanical inclusions is achieved by filtering the injection solutions through a suitable filter material. In pharmaceutical practice for filtering injectable solutions the most common filters are membrane-type filters with a pore size of 0.45 to 1.0  $\mu\text{m}$  for pre-filtration and 0.2  $\mu\text{m}$  for sterilizing filtration<sup>14</sup>. Filtration through a system of membrane filters with a pore size of 1.0  $\mu\text{m}$  - 0.2  $\mu\text{m}$  allows you to combine the processes of injection solutions sterilization and removal of mechanical inclusions.

Among all the areas of applications for the purification and separation of membrane filters liquids used in the manufacture of medicines are characterized by the strictest quality requirements and conditions of their production and use. Filters for aseptic production of injectable solutions in polyethylene ampoules are the only possible method of sterilization<sup>15, 16</sup>. Such increased attention to the process of sterilizing filtration is also explained by the fact that filtration is still a rather risky method of sterilization. The purpose of sterilizing filtration in aseptic conditions of pharmaceutical medicines is not only the removal of mechanical particles. It also means the removal of all living microorganisms out of the solutions<sup>17</sup>. Validation of the sterilizing filtration process should be confirmed in regard to the ability of the filter element to sterilize the product<sup>18</sup>.

Since the production of injectable medicines in polyethylene ampoules does not involve the process of thermal sterilization in the primary packaging<sup>19,20</sup>, the reliability of the filtration process. It has been achieved by performing certain tests, significantly affects the production of the finished product of proper quality.

The **aim** of the research was to substantiate the methodological approach to the development of the filtration process of solutions containing substances of different chemical structures, using a prepared solution of piracetam. To the purpose the experience of pharmaceutical development for med-

icines in polyethylene ampoules, implemented in the Joint-stock company "NIKO" (JSC NIKO COMPANY, Ukraine), was considered.

## 2. Materials and Methods.

### 2.1 Materials.

The research object was a solution of piracetam 20% prepared in the experimental laboratory JSC NIKO COMPANY, Ukraine. As well as filter membranes, were made of materials based on: polyvinylidene difluoride, "Durapore" (catalog number GSVWP 04700), manufactured by the company «Millipore», USA; polyester sulfone, «PROPOR PES» (catalog number ZDMS-047-020AZ), manufactured by the company «Parker Domnick hynter ltd», United Kingdom; nylon, «Ultipor N 66» (catalog number AB1NF7PH4), manufactured by the company «Pall», Germany.

### 2.2 Methods.

All studies have been performed using the methods according to the State Pharmacopoeia of Ukraine of the second edition<sup>9</sup>:

#### 2.2.1. Determination of the degree coloration of the piracetam solution 20%.

2.0 ml of the test liquid is compared with 2.0 ml of water using identical colorless clear neutral glass test tubes with an outer diameter of 12 mm. Color comparisons are performed in diffused daylight by looking at the samples horizontally on a white background.

#### 2.2.2. Potentiometric determination pH of the piracetam solution 20%.

Potentiometric pH determination is performed by measuring the potential difference between two respective electrodes immersed in the test solution. One of the electrodes is sensitive to hydrogen ions (usually a glass electrode). The other one is a reference electrode (for example, a saturated calomel electrode). The measuring device is a voltmeter with an input resistance at least 100 times greater than

the resistance of the electrodes used. All measurements are performed at the same temperature in the range from 20 °C to 25 °C. The device is calibrated using a buffer solution of potassium hydrophthalate (primary standard) and one of the buffer solutions with a different pH value. The readings of the instrument for the third buffer solution with an intermediate pH value should not differ by more than 0.05 pH units from the tabular pH value of the piracetam solution 20%. The electrodes are immersed in a piracetam solution 20% and the pH is measured under the same conditions as for the buffer solutions. All test solutions and standard buffer solutions should be prepared in water free of carbon dioxide.

#### 2.2.3. Quantitative determination of piracetam.

The method of high-performance liquid chromatography (HPLC) was applied for the quantitative determination of piracetam. Chromatography was performed on a liquid chromatograph with an ultraviolet detector under the following conditions. Detection at a wavelength of 205 nm; column Luna C 18 size 250x4.6 mm with a column temperature of 50 °C; mobile phase: dipotassium hydrogen phosphate with a pH of  $6.0 \pm 0.05$ , adjusted by dilute phosphoric acid - acetonitrile (95:5); the speed of the mobile phase is 0.5 ml/min.

#### 2.2.4. Determination of sterilizing suitability of filter material.

Verification the sterilizing ability of the filter was conducted by the method of membrane filtration using a filter device (**Figure 1**). The tests were performed in a clean Class D room in the biosafety box (zone A). Test cultures of *Brevundimonas diminuta* bacteria were used to test the sterilizing ability of the filter. After completion filtration of the test solution of piracetam 20%, the membrane filter was washed in three portions of 100 ml of washing liquid and in its last portion was made a suspension of the test strain of *Brevundimonas diminuta* bacteria.

After filtration, membrane filters were placed in Petri dishes on the surface of the medium soybean

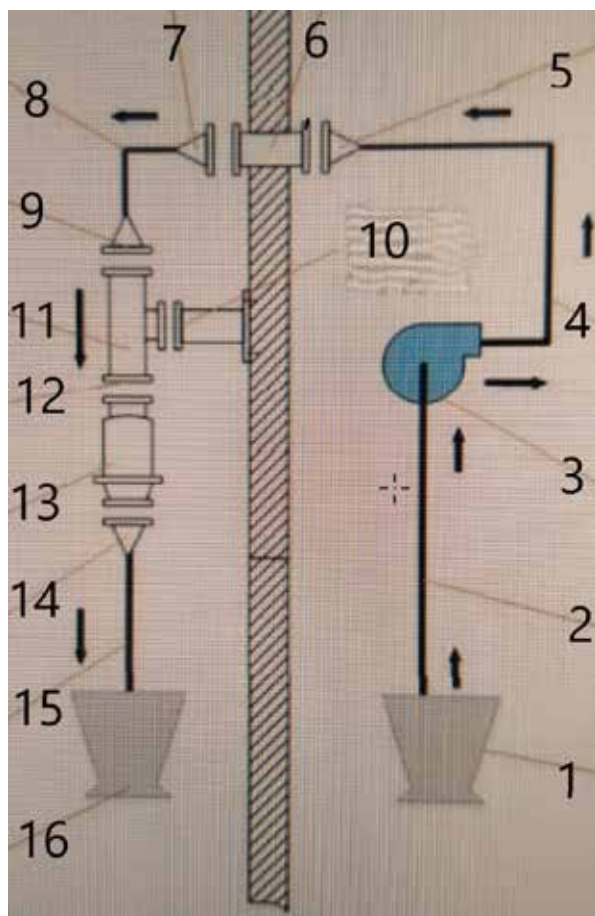

**Figure 1.** Scheme of the filter device for membrane filtration method:

1 - Container with solution; 2, 4 - Hose №1; 3 - Peristaltic pump; 5, 7, 9, 10, 12, 14 - Terminal connection to the fitting; 6 - Passing port; 8 - Hose №2; 11 - Filter holder; 13 - Filter with housing; 15 - Hose №3; 16 - Container with sterile solution.

agar. Incubate for 3-5 days at the temperature from 30°C to 35°C. For a positive control experiment through membrane filters of 0.45 µm was passed 100 ml of washing liquid (buffer solution with sodium chloride and peptone pH 7.0) with a suspension of test culture of bacteria *Brevundimonas diminuta*. After filtration, membrane filters were placed on the surface of the medium soybean casein agar in Petri dishes. Incubation of the filters was performed simultaneously with the test samples at the tempera-

ture of from 30°C to 35°C for 3-5 days.

Accepter criterion: - no growth of *Brevundimonas diminuta* in the studied samples; - the presence of growth of *Brevundimonas diminuta* in the positive control.

#### 2.2.5. Gravimetric determination of dry residue after evaporation.

Thermogravimetric analysis was performed on a derivatograph of the system F. Paulik, I. Paulik, L. Efdel with platinum/platinum-rhodium thermocouple when heating the samples in ceramic crucibles from 20 to 300°C in the air.

The heating rate was 5°C per minute. The standard was hardened aluminium oxide, the weight of the samples was 50 mg.

#### 2.2.6. Test for mechanical inclusions by light blocking method.

A suitable device based on light blocking principle, which allows to measure automatically the number and the size of particles were used. The instrument is calibrated using suitable certified reference materials consisting of dispersions of spherical particles of certain sizes - 10 µm and 25 µm. Such standard particles are dispersed in water free of particles, R. Measures should be taken to avoid aggregation of the particles during dispersion. The contents of the sample were mixed by inverting slowly and continuously the container 20 times. If necessary, remove carefully the packaging. The outer surfaces of the opening container were cleaned with a jet of water free of particles, P and opened the container, avoiding any contamination., A suitable procedure was used to remove air bubbles (settling the solution for 2 min or sonication). Because the parenteral drug used is small in volume, less than 25 ml, 10 or more dosage units were combined in a clean container to obtain a volume of at least 25 ml. The number of test samples was taken sufficient to provide a statistically sound estimate. Four samples, not less than 5 ml each, were taken and the number of particles with sizes equal to or greater than 10 µm and 25 µm was

determined. The result obtained for the first sample has been excluded and the average number of particles in the test sample has been calculated.

### 3. Results and Discussion.

At the first stage of research, the study of the chemical compatibility of the solution and filter materials has been carried out under dynamic conditions (by filtering the solution through selected filter membranes). During studying the chemical compatibility of the solution and filter materials, the quality of the solution has been controlled by the following indicators: transparency, color, pH, quantitative content of the active substance (**Table 1**).

In the second stage, the content of substances extracted into the filtrate has been determined. A sterilizing filter of company «Parker Domnick hunter ltd.», to perform this test of trade mark PROPOR PES (ZDMS090-020-AY) DISC (filtration material: polyester sulfone with a rating of 0.2  $\mu\text{m}$ ) was used.

During the test, the solution was conducted to

determine the content of substances extracted into the filtrate. To assess the possible migration of potential products of the filter material to the prepared solution, 2 samples in the amount of 0.5 l each were investigated (the first sample - after contact for 4 hours with the filter; the second sample - control, without contact with the filter).

The samples were analyzed according to the following indicators:

- Gravimetric determination of dry residue after evaporation;
- Comparison of impurities profile of the active substance in the solution;
- Evaluation of the infrared spectra of the dry residue after evaporation;
- Sterilizing suitability of the filter;
- Determination of the filtration efficiency of the injectable solution.

The results obtained in determining the effect of the filter material on the test solution of piracetam 20% are presented in **Table 2** and **Figures 2-5**.

Thus, the conducted research showed that the

**Table 1: The effect of filter materials on the quality of the test solution of piracetam 20%**

Original	Filter material		
	nylon	polyvinylidene difluoride	polyester sulfon
<i>Transparency (should be transparent)</i>			
not transparent	transparent	transparent	transparent
<i>Chromaticity (not more intense than the standard BY<sub>7</sub>)</i>			
corresponds	corresponds	corresponds	corresponds
<i>pH (from 5.0 to 7.0)</i>			
5.96	5.97	5.96	5.96
<i>Quantitative content of piracetam, mg/ml (from 190.0 to 210.0)</i>			
200.3	200.4	200.3	200.3

**Table 2: Determination of dry residue of prepared and filtered solution of piracetam 20%**

The name of the test	The parameter being evaluated	Acceptability criteria	Result	
Determination of dry residue	The amount of dry residue after evaporation in terms of 1 ml	Minimum difference in the amount (or absence) of dry residue	Dry residue of the solution before filtration <u>200.2 mg/ml</u>	Dry residue of the solution after filtration <u>200.1 mg/ml</u>

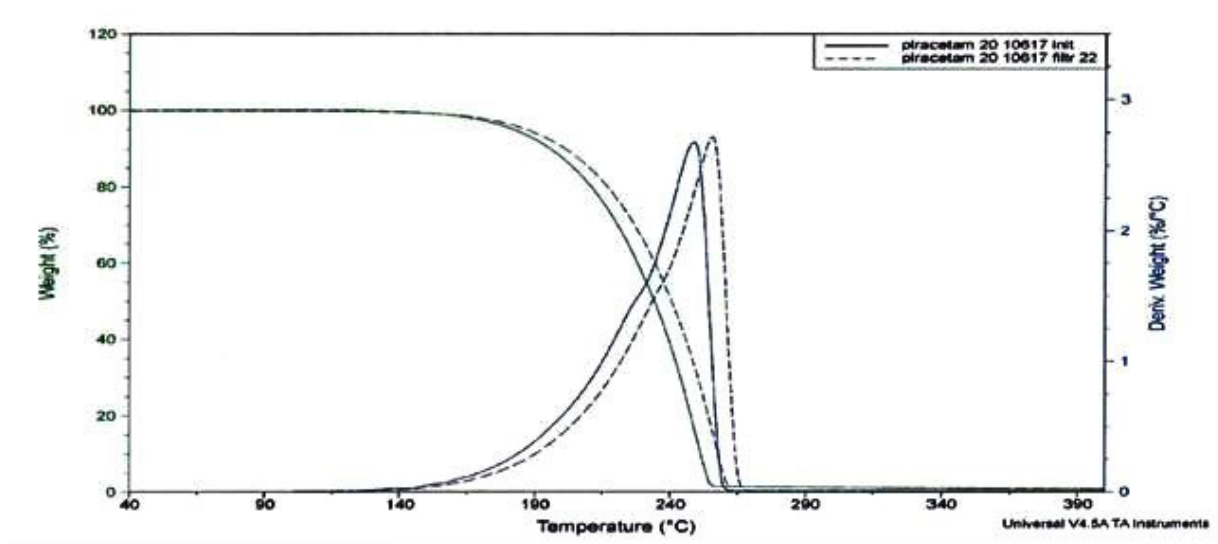

Figure 2. Thermogram of dry residues of the prepared solution of piracetam 20% before and after filtration

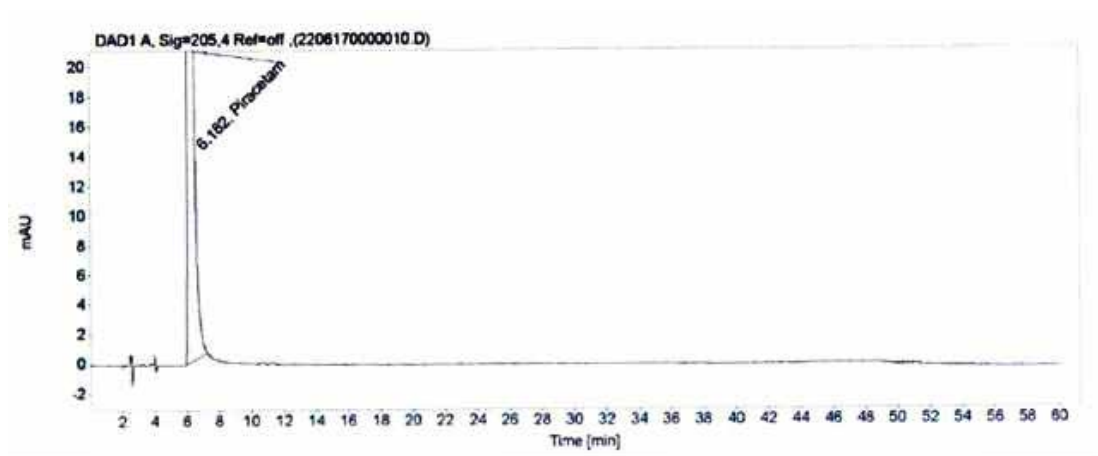
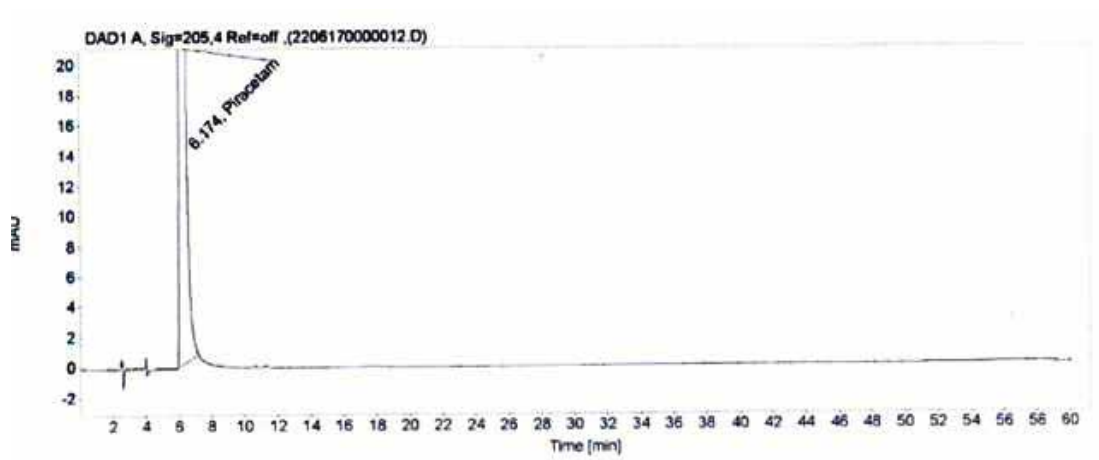
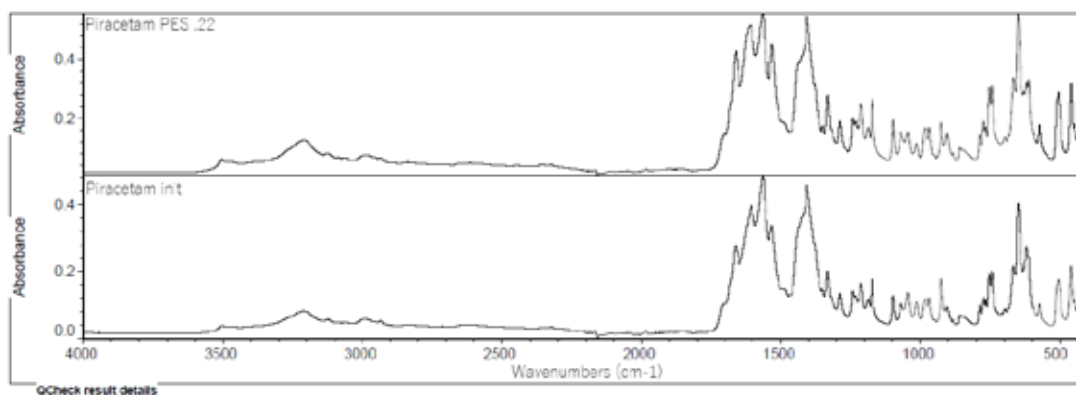

Figure 3. Profile of impurities of piracetam solution 20% before filtration



**Figure 4.** The profile of impurities of piracetam solution 20% after filtration through a filter with a polyester sulfone filter material with a rating of 0.2  $\mu\text{m}$



**Figure 5.** Infrared spectra of dry residues of piracetam solution 20% before (lower spectrum) and after (upper spectrum) filtration

dry residue of the prepared solution before and after filtration is practically unchanged. The profile of impurities of both prepared and filtered solution coincides. The infrared spectra of dry residues before and after filtration are identical. It proves no effect of filter material and no diffusion the filter material substances to the investigated solution under selected filtration conditions.

Determination of the sterilizing suitability of the filter material has been performed using a bacterial test, evaluating whether the sterilizing filter provides sterile filtrate during filtration and after filtration of the entire amount of prepared solution of pi-

racetam 20% under appropriate process conditions (that is, after contact of the filtration membrane with the investigated solution for the time determined by the technology). The testing procedure is based on the results of the viability test. Acceptability criteria of the test is absence of growth test-microorganism *Brevundimonas diminuta* on an analytical filter in the studied samples. The level of bacterial load for the test filter should be below the allowable validated limit ( $\times 10^{11}$ ). It minimizes the potential of non-sterile product and ensures the sterility of the product after filtration. The test results are presented in **Table 3**.

**Table 3: Determination of the sterilizing ability of the filter using test microorganisms**

Filter Part Number/ Lot Number	Total challenge (CFU)	Challenge per filter area (CFU/cm <sup>2</sup> )	Recovery, CFU
Pall PANX047100/ UA6231	3.82x10 <sup>9</sup>	2.2x10 <sup>8</sup>	0
Durapore AB05DFL2PH4/ IT6225	3.82x10 <sup>9</sup>	2.2x10 <sup>8</sup>	0
PROPOR PES ZCMS1-020C- PS/1406231	3.82x10 <sup>9</sup>	2.2x10 <sup>8</sup>	0

**Table 4: Determination of invisible particles in a filtered solution of piracetam 20%**

Run No.	Particle size (µm)	Cumulative count	Particles per container
Run 1	10.000	203.00	406.00
	25.000	4.00	8.00
Run 2	10.000	143.00	286.00
	25.000	2.00	4.00
Run 3	10.000	229.00	458.00
	25.000	4.00	8.00
Run 4	10.000	161.00	322.00
	25.000	2.00	4.00
Average	10.000	177.67	355.33
		2.67	5.33

*Notes:**Sample volume (mL) : 5**No. of runs : 4**No. of containers : 10**Total pooled volume (mL): 100**Container volume (mL): 10**Dilution factor : 1**Run1 : Discarded*



The filtration efficiency has been determined by the method of light blocking on the device «Liquid particle counting system of company Hiac Royco», USA.

**Table 4** shows studies to test the invisible particles of a solution of piracetam 20%, which was filtered through a PES membrane with a rating of 0.2  $\mu\text{m}$ .

It can be seen from table 4 the number of particles in the test sample meets the requirements of State Pharmacopoeia of Ukraine 2.9.19, method 1 at a regulated limit of 6000 in an ampoule for particles with a size of 10  $\mu\text{m}$  or more and not exceeding 600 particles with a size of 25  $\mu\text{m}$  or more. The research has carried out the proofs that the use of the investigated filter material allows to obtain a solution of the required quality.

#### 4. Conclusions

The complex of researches during holding one of pharmaceutical development stages of technological process, namely the stage of filtration for injectable medicines (on the example of injectable solution of piracetam of 20%) has been defined.

Conducted research of mutual influence of filter material with a solution has proven that pH of the solution before and after filtration doesn't change, indicating the compatibility of the solution with a filter. The selected filters correspond to the pH range of the piracetam solution 20%. Determination of the

quantitative content of the active substance of piracetam before and after filtration (within the regulated limits) determined the absence of sorption of the active substance on the filter.

Profile impurities solution before and after filtration are identical. No additional peaks are observed infrared spectra of the dry residue obtained after evaporation of prepared and filtered solutions. It is virtually the same profile that indicates the absence of substances extracted from washed and filter the solution. Control of sterilizing ability of filters by the test to restrain the growth test culture of bacteria *Brevundimonas diminuta* showed no growth of test culture, the level of bacterial load for the studied filters was below the validated limit ( $\times 10^{11}$ ). It minimizes the potential of non-sterile product and ensures sterility after filtration.

The completeness of the research carried out at the phase of pharmaceutical development of the filtration stage will minimize the risks of exposure to the filter material on the solution, identify critical control points at this stage to prevent poor quality products in industrial production.  $\square$

**Conflict of Interest.** The authors declare that they have no conflict of interest.

ORCID iDs *Viacheslav Shevchenko* <https://orcid.org/0000-0003-3078-1744>

*Svitlana Rolik-Attia* <https://orcid.org/0000-0002-0299-5895>

*Yevhen Bezrukavyyi* <https://orcid.org/0000-0001-7527-9788>

#### REFERENCES

1. Bukofzer S., Ayres J., Chavez A. et al. Industry perspective on the medical risk of visible particles in injectable drug products. *PDA J. Pharm. Sci. Technol.* 69 (1), 123-39, 2015.
2. Perez M., Maiguy-Foinard A., Barthélémy Ch., Décaudin B., Odou P. Particulate Matter in Injectable Drugs: Evaluation of Risks to Patients. *Pharm. Technol. Hosp. Pharm.* 1 (2), 91-103, 2016.
3. Thomas S., Mahendran S., Selvakumar R. Formulation and evaluation of an injectable solution as a dosage form. *JDDT.* 8(5), 81-87, 2018.
4. Trissel L.A. (2015) Handbook on injectable drugs, 18th ed. *Bethesda: American Society of Health-System Pharmacy*, 1280 p.
5. Langille S. Particulate Matter in Injectable Drug Products. *PDA J. Pharm. Sci. Technol.* 67(3), 186-200, 2013.
6. Akers M.J. (2016) Sterile Drug Products: Formulation, Packaging, Manufacturing and Quality. *USA: CRC Press*, 516 p.

7. Bennett A. Pharmaceuticals and fine chemicals: Filtration and separation in the diverse fine chemical sectors. *Filtration+Separation*. 50 (6), 30-33, 2013.
8. Gulyakin I.D., Nikolaeva L.L., Sanarova E.V., Lantsova A.V., Oborotova N.A. Primeneniye membrannykh fil'trov v tekhnologii polucheniya steril'nykh lekarstvennykh form [The use of membrane filters in the technology of obtaining sterile dosage forms]. *Himiko-farmatsevticheskiy zhurnal*. 50 (1), 28-32, 2016 [in Russian].
9. State Pharmacopoeia of Ukraine: in 3 vol. (2015). 2nd ed. *Kharkiv, Ukrainian Scientific Pharmacopoeial Center for Drug Quality*, vol.1, 1128 p.
10. McKinnon B.T., Avis K.E. Membrane filtration of pharmaceutical solutions. *Amer. J Hosp. Pharm.*, 50 (9), 1921-36, 1993.
11. Langille S.E. Particulate matter in injectable drug products. *PDA J. Pharm. Sci Technol*. 67 (3), 186-200, 2013.
12. Belgaid A., Benaji B., Aadil N. et al. Sterilisation of aseptic drug by sterile filtration: Microbiology validation by microbiology challenge test. *J. Chem. Pharm. Res*. 6 (12), 760-70, 2014.
13. Sumitra A.P., Dhawal Ch., Dileep U., Nagasuri R. Filters and Filtration: A Review of Mechanisms That Impact Cost, Product Quality and Patient Safety. *J. Pharm. Sci. & Res*. 8 (5), 271-8, 2016.
14. Shevchenko V.O., Rolik-Attia S.M., Shpychak O.S., Andryukova L.M., Fetisova O.H. (2020). Metodolohiya rozrobky protsesu fil'tratsiyi in "yektsiynoho likars'koho zasobu na prykladi rozchynu piratsetamu 20% [Methodology for developing the filtration process of injectable medicine on the example of a piracetam solution 20%]. Application of methods of treatment and apipreparations in medical, pharmaceutical and cosmetic practice: materials of the international scientific-practical conference devoted to memory of academician of UAS O.I.Tikhonov (Kharkiv, March 25, 2020). *Kharkiv, NFaU publishing house*, pp. 233-235 [in Ukrainian].
15. Safaraz K. Niazi (2016) Handbook of Pharmaceutical Manufacturing Formulations: Sterile Products. USA: CRC Press, 464 p.
16. Rashed A.M., Hetta A.M., Hashem Z.S., El-Katatny M.H. Validation of moist and dry heat processes used for sterilization and depyrogenation during ampoules manufacturing. *J. Adv. Biomed. & Pharm. Sci*. 3, 177-83, 2020.
17. Meltzer Th.H., Jornitz M.W. The Sterilizing Filter and Its Pore Size Rating. *Am.Pharm.Rev*. 6( 3), 44-52, 2003.
18. Tarasov A.V., Tarasova S.A., Andreyev S.V., Rogozhkin Ye.V., Kondrashkov D.O. Validatsiya protsesa sterilizuyushchey fil'tratsii v proizvodstve gotovykh lekarstvennykh sredstv [Validation of the sterilizing filtration process in the production of finished pharmaceutical products]. *Farmatsevticheskiye tekhnologii i upakovka*. 6, 66-67, 2013 [in Russian].
19. Zadbuke N., Shahi S., Gulecha B. et al. Recent trends and future of pharmaceutical packaging technology. *J. Pharm. Bioallied Sci*. 5(2): 98-110, 2013.
20. Costa R.C., Pereira E.D., Silva F.M. et al. Drug micro-carriers based on polymers and their sterilization. *Chem. Chem. Technol*. 12 (4), 473-87, 2018.